

## Ford Lehman Engines

Earlier models of the Ford Lehman engine had an SAE tachometer drive fitting installed on the starboard side of the engine block midships fore and aft just above the oil pan. Our model 8901 sender will connect to this fitting and may be used with any model of our standard tachometer. The sender turns at  $\frac{1}{2}$  engine speed so all three switches are left in the off position.

After about 1977 Lehman began leaving the tach drive fitting off and closing of the resulting hole with a dust cover that looks like a freeze plug. Our model 8619 Lehman tach drive adapter will replace the parts Lehman left off. It is a simple matter to install it, remove the dust cover, drop the center drive piece into the hole and fasten the mounting boss plate with two  $\frac{1}{4}$ " cap screws.

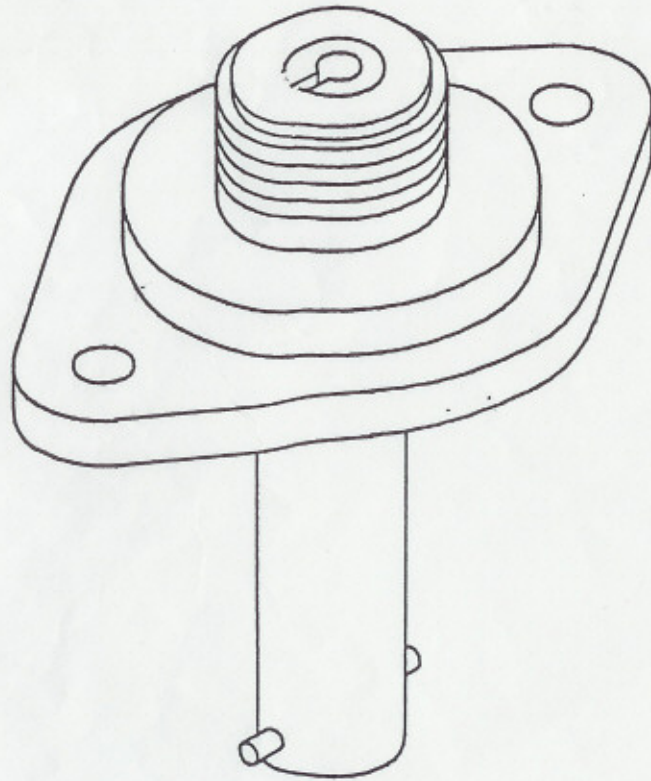

Location where adapter is to be installed  
On back of sheet

### Installation Instructions

- 1) Remove existing cup type expansion plug on engine
- 2) Install shaft making sure that the pin slides into slots in the engine
- 3) Install gasket and plate using cap screws and lockwashers provided

Grease the part of the shaft that goes into our plate

Make sure that shaft has end play (Up and down) after tightening

D 160 DRIVE ADAPTER

SCALE: FULL

DATE: 4/12/88

PART # 06061

Aetna Engineering



# INDEX TO LEHMAN MARINE EQUIPMENT

AETNA P/N 8619

## PICTORIAL INDEX

PAGE NUMBERS ARE SHOWN ON DRAWINGS BELOW

